

Hand pallet truck 0.75 t

BT lifter

L-series

LHM075H



Hand pallet truck

Truck specifications					LHM075H
Identification	1.1	Manufacturer			Toyota
	1.2	Manufacturer's type designation			LHM075H
		Fork length		mm	950
	1.4	Operator type			Hand
	1.5	Load capacity/rated load	Q(t)	kg	750
	1.6	Load centre distance	c	mm	400
	1.8	Load distance, centre of drive axle to fork	x	mm	745 ¹⁾
	1.9	Wheelbase	y	mm	1170 ¹⁾
Weight	2.1	Service weight		kg	58
	2.2	Axle load, with load, drive/castor/fork wheel		kg	120/260
	2.3	Axle load, without load, drive/castor/fork wheel		kg	20-10
Wheels	3.1	Steer/fork/support wheels: Powerthane (Po), Steel (S) Nylon (N), Polyurethane (P), Rubber (R), Rubber antistatic (Ra)			Po, S, N, P, R, Ra/ Po, S, N, P
	3.2	Wheel size, front			175x60
	3.3	Wheel size, rear			85x75
	3.5	Wheels, number front/rear (x = driven wheels)			2/2
	3.6	Track width, front	b_{10}	mm	132
	3.7	Track width, rear	b_{11}	mm	340
	Dimensions	4.4	Lift	h_3	mm
		Lift height	h_{23}	mm	200
4.9		Height of tiller in drive position, min./max.	h_{14}	mm	1220
4.15		Height, lowered	h_{13}	mm	85
4.19		Overall length	l_1	mm	1500
4.20		Length to face of forks	l_2	mm	365
4.21		Overall width	b_1	mm	520
4.22		Fork dimensions	s/e/l	mm	45/110/950 ²⁾
4.25		Width over forks	b_5	mm	450
4.32		Ground clearance, centre of wheelbase	m_2	mm	40
4.33		Aisle width for pallets 1000x1200 crossways	A_{st}	mm	1544 ¹⁾
4.34		Aisle width for pallets 800x1200 lengthways	A_{st}	mm	1544 ¹⁾
4.35		Turning radius	W_a	mm	1175 ¹⁾

1) Distance with forks raised.

2) Other fork lengths are available on request.

All data are based on table configuration. Other configurations may give other values.

Truck performance and dimensions are nominal and subject to tolerances.

Toyota Material Handling Manufacturing Sweden AB products and specifications are subject to change without notice.

Dimensional drawings

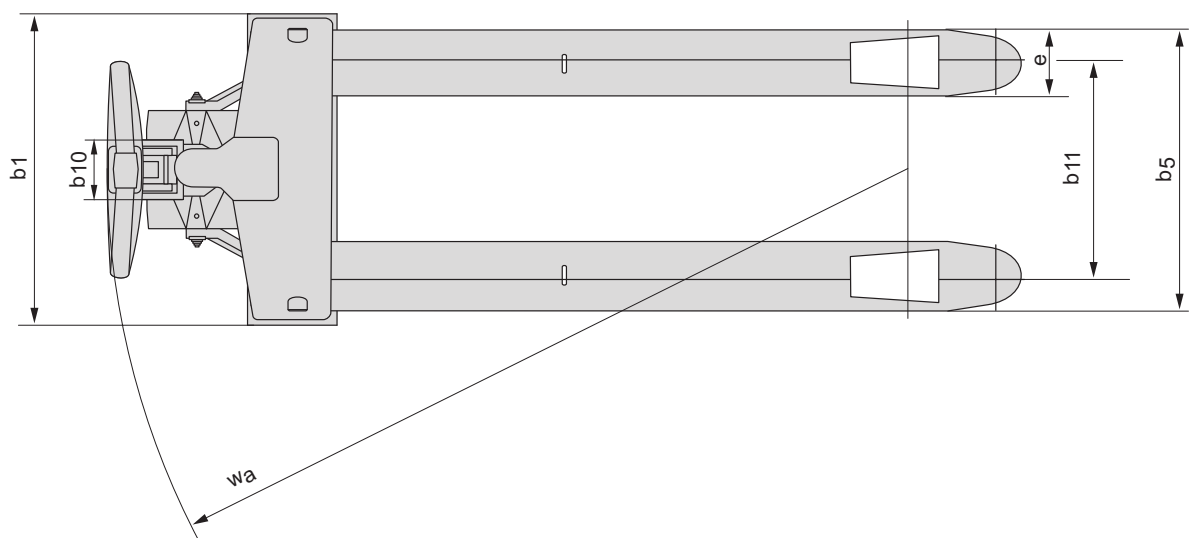
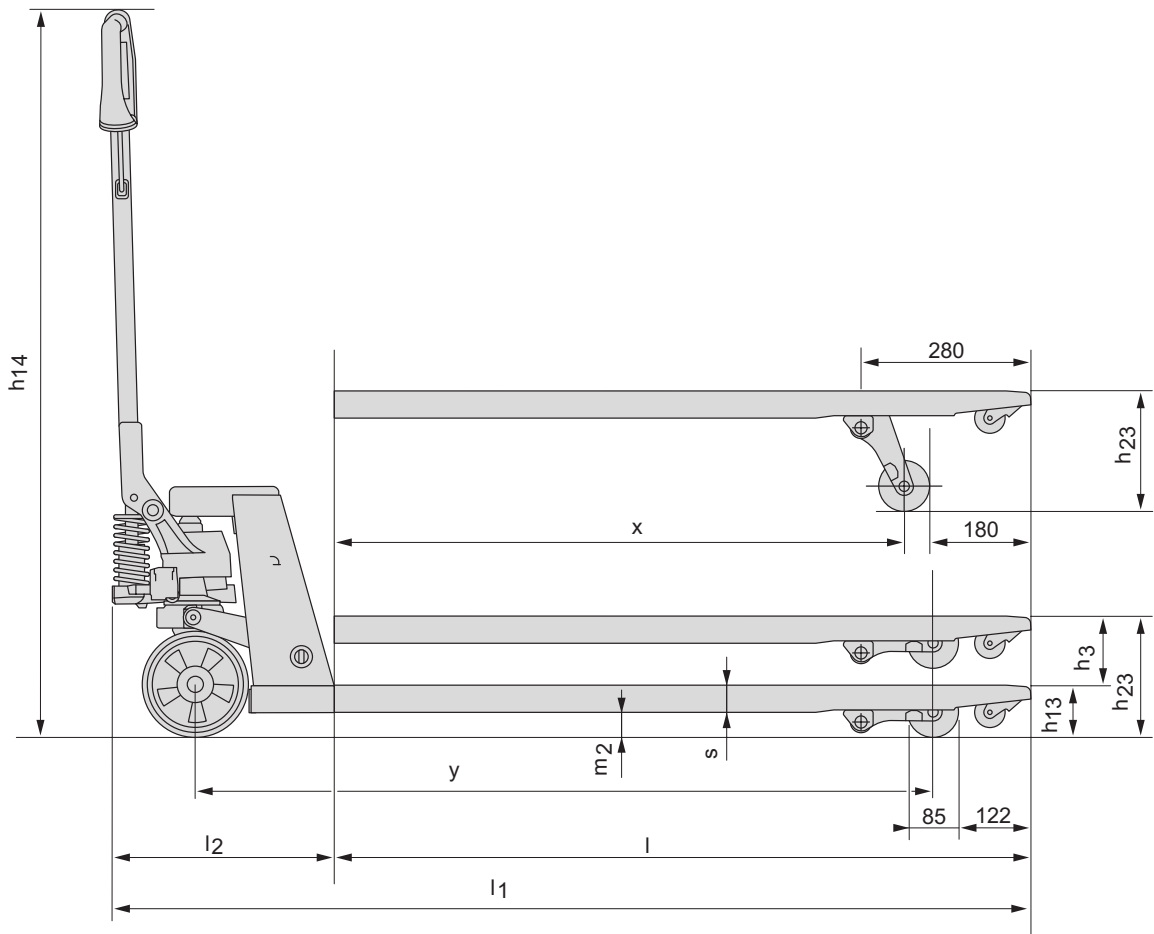

Truck features:

- This BT Lifter has been specially adapted for handling of different types of half pallets.
- Robust design and still low weight – easy to manoeuvre.
- Powder coating and robot welding give a high and even finish.
- Angled high strength polymer handle for best ergonomic grip.
- BT lowering control valve enables smooth, controlled lowering action.
- Strong powerful thrust bearing is standard, for easier steering and enhanced durability.
- Greasable bushings ensure long service life.
- Quick lift and overload can be combined.
- Customized configurations – a part of our offer.



TP-Technical Publications, Sweden — 745354-040, version 1, 1202